

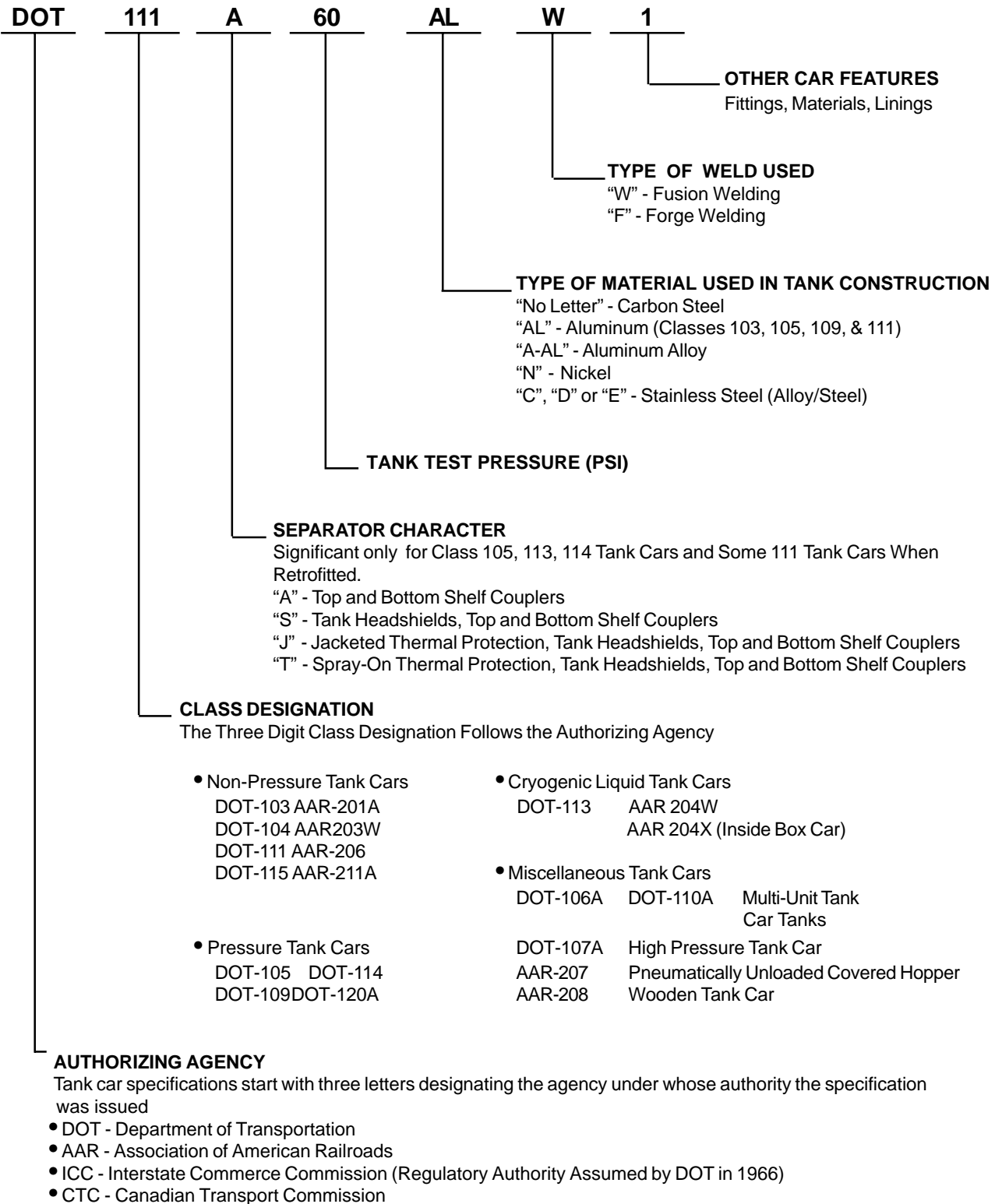

# **Silhouettes of Rail Cars, Tank Trucks and Chemical Tanks**

# Railroad Tank Car Marking System



# Pressure Cars

Pressure cars are used to transport hazardous materials under pressure or hazardous materials which the DOT or the shipper feel require the additional protection of a stronger car. The most common types of pressurized cars used in rail transportation are the DOT 105, 112 and 114. Drawings of 105's and 112's can be found in this Appendix. The DOT 114 is the same as the DOT 112 except that the 112 has bottom outlets and washouts. DOT Car Types 107 And 109 are also pressurized cars. DOT Types 106 and 110 pressurized, multi-unit tank cars are one-ton cylinders which can also be transported by highway. As a general rule, safety valves are set at a pressure to match vapor pressure of product at 105° F.

| TANK DESCRIPTION  | TYPICAL COMMODITIES TRANSPORTED<br>(typical commodities only listed, there may be others)   |
|---|---|
| <b>A-3 — Class 105</b>  |   |
| <b>DOT 105J100W</b><br>Thermal Protection.<br>Head Protection.<br>Safety Valves (75 psi). | Ethylene Oxide<br>Liquefied Petroleum Gas<br>Liquefied Hydrocarbon Gas  |
| <b>DOT 105J200W</b><br>Thermal Protection.<br>Head Protection.<br>Safety Valve (150 psi). | Sulfur Dioxide<br>Vinyl Chloride<br>Liquefied Petroleum Gas   |
| <b>DOT 105J300W</b><br>Thermal Protection.<br>Head Protection.<br>Safety Valve (225 psi). | Anhydrous Hydrofluoric Acid<br>Anhydrous Ammonia<br>Metallic Sodium<br>Chlorine<br>Liquefied Petroleum Gas<br>Liquefied Hydrocarbon Gas<br>Motor Fuel Anti-Knock Compound<br>Vinyl Chloride |
| <b>DOT 105J400W</b><br>Thermal Protection.<br>Head Protection.<br>Safety Valve (300 psi). | Liquefied Petroleum Gas<br>Liquefied Hydrocarbon Gas  |
| <b>DOT 105A500W - Hydrogen Cyanide (Hydrocyanic Acid), HCN</b>                            |   |

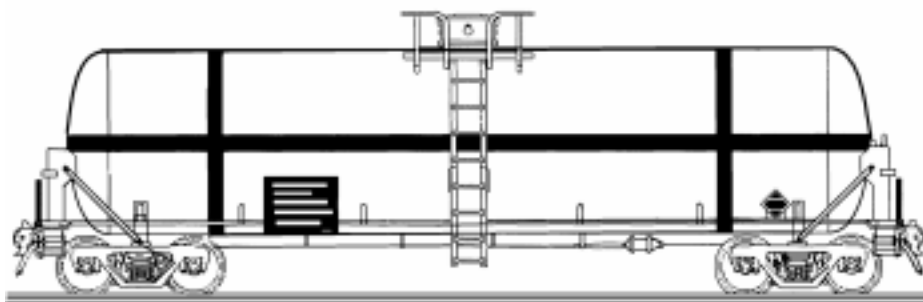

B-END

Hydrogen Cyanide is shipped in specially built cars. Pictured is a 105A500W 20,500-gallon capacity. Other cars used are the 105A600W and the 105J600W. For safety purposes, the cars may be stenciled as 300W, but have the higher-pressure safety valves. These cars have a 1-1/8" thick inner shell, 4" of cork insulation and a 1/4" outer shell. **Some HCN cars will be painted white with the red bands or "candystripes."**

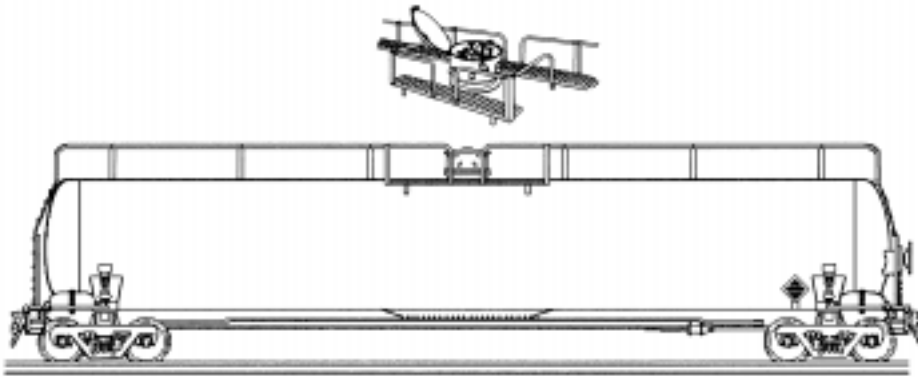
**TANK DESCRIPTION****TYPICAL COMMODITIES TRANSPORTED**  
(typical commodities only listed, there may be others)**DOT 105A500W Insulated — Carbon Dioxide Service**

**20,000 GALLON CAPACITY - INSULATED  
DOT 105A500W  
FOR CARBON DIOXIDE SERVICE  
(PRE 1983)**

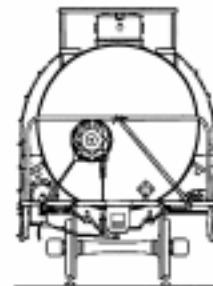
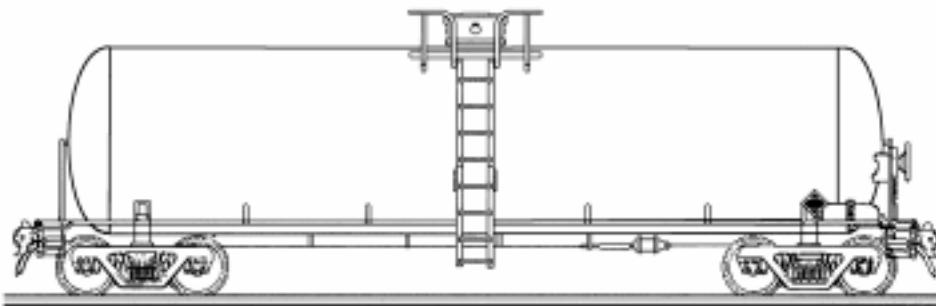
**B-END****DOT 105A500W Insulated — Chlorine Service**

**90 TON CAPACITY - INSULATED  
DOT 105A500W  
FOR CHLORINE SERVICE  
(POST 1982)**

**B-END**

Insulated.

Safety Valve (375 psi) (350 psi on Carbon Dioxide Cars)

Chlorine

Carbon Dioxide

Anhydrous Hydrofluoric Acid

**DOT 105J500W**

Thermal Protection.

Head Protection

Safety Valve (375 psi)

Liquefied Petroleum Gas

Liquefied Hydrocarbon Gas

**DOT 105A600W**

Insulated.

Safety Valve (450 psi) (400 psi on Carbon Dioxide Cars).

Carbon Dioxide

**DOT 105J600W**

Thermal Protection.

Head Protection.

Safety Valve (450 psi)

Liquefied Petroleum Gas

Liquefied Hydrocarbon Gas

**DOT 105A100ALW**

Insulated.

Safety Valve (75 psi).

Fertilizer Ammoniating Solution

(Ammonium Nitrate Solution)

| TANK DESCRIPTION   | TYPICAL COMMODITIES TRANSPORTED<br>(typical commodities only listed, there may be others)       |
|--|---|
| <b>DOT 105A200ALW</b><br>Insulated.<br>Safety Valve (150 psi).   | Fertilizer Ammoniating Solution<br>(Ammonium Nitrate Solution)                                  |
| <b>DOT 105A300ALW</b><br>Insulated.<br>Safety Valve (225 psi).   | Fertilizer Ammoniating Solution<br>(Ammonium Nitrate Solution)                                  |
| <b>A-4 — Class 106A (Similar to 110A Tanks)</b>  |   |
| <b>DOT 106A500X</b><br>Multiple Unit with Removable Steel<br>Uninsulated Tanks. Each Tank equipped<br>with Loading and Discharge Valve & Safety<br>Valve or Vent Set for Pressure not Exceeding<br>375 psi. Popular Name is “Ton Container”.             | Chlorine<br>Anhydrous Ammonia<br>Sulfur Dioxide<br>Butadiene<br>Refrigerant or Dispersant Gases |
| <b>DOT 106A800X</b><br>Multiple Unit with Removable Steel, Uninsulated<br>Tanks Mounted on Underframe. Popular name is “Ton<br>Container”. Each Tank equipped with Loading and Discharge<br>Valves & Safety Vent Set for Pressure not Exceeding 600 psi. | Nitrosyl Chloride   |
| <b>A-5 — Class DOT 107A</b>  |   |
| <b>DOT 107A*****</b><br>Multiple Unit Uninsulated High Pressure<br>Seamless Forged & Drawn Steel Tanks.<br>About 30 Permanently Mounted on Underframe  | Helium<br>Hydrogen<br>Oxygen  |
| <b>A-6 — Class DOT 109A</b>  |   |
| <b>DOT 109A300W</b><br>Non-Insulated or Insulated.<br>Safety Valve (225 psi).  | Nitrogen Fertilizer Solution<br>(Ammonium Nitrate Solution)<br>or 115° F [non-insulated])       |
| <b>DOT 109A100ALW</b><br>Non-Insulated or Insulated.<br>Safety Valve (75 psi).   | Nitrogen Fertilizer Solution<br>(Ammonium Nitrate Solution)                                     |
| <b>DOT 109A200ALW</b><br>Non-Insulated or Insulated<br>Safety Valve (150 psi).   | Nitrogen Fertilizer Solution<br>(Ammonium Nitrate Solution)                                     |
| <b>DOT 109A300ALW</b><br>Non-Insulated or Insulated.<br>Safety Valve (225 psi).  | Nitrogen Fertilizer Solution<br>Ammonium Nitrate Solution)                                      |
| <b>A-7 — Class DOT110A (Similar to 106A Tanks)</b>   |   |
| <b>DOT 110A500W</b><br>Multiple Unit with Removable Steel Tanks Mounted<br>on Underframe. Popular name is “Ton Container”.<br>Each Tank equipped with Loading & Discharge<br>Valves & Safety Valve or Vent Not Exceeding 375 psi                         | Sulfur Dioxide<br>Refrigerants  |
| <b>DOT 110A800W</b><br>Multiple Unit with Removable Steel Tanks Mounted<br>on Underframe. Popular name is “Ton Container”.<br>Each Tank equipped with Loading & Discharge<br>Valves & Safety Valve or Vent Not Exceeding 600 psi                         | Monobromotrifluoromethane   |
| <b>A-9 — Class DOT 111A 112A, 112S, 112J, 112T</b>   |   |
| <b>DOT 112A200W</b><br>Non-Insulated (Upper 2/3 of Tank Must<br>be painted with Light-Reflective Paint).<br>Safety Valve (150 psi).  | Ethyl Chloride  |
| <b>DOT 112A340W</b><br>Non-Insulated (Upper 2/3 of Tank Must be painted with Light-Reflective Paint).<br>Safety Valve (225 psi); Alternate setting 280.5 psi for Certain Commodities   |   |
| <b>DOT 112S340W</b><br>Same as DOT 112A340W Except<br>Equipped with Head Protection  | Anhydrous Ammonia   |
| <b>DOT 112J340W</b><br>Same as DOT 112A340W Except Equipped with<br>Head Protection and a Thermal Protection Enclosed<br>in a Metal Jacket. No Reflective Paint Required   | Liquefied Petroleum Gas   |

**TANK DESCRIPTION****TYPICAL COMMODITIES TRANSPORTED**  
(typical commodities only listed, there may be others)**DOT 112T340W**

Same as DOT 112A340W Except Equipped with Head Protection and a Non-Jacket Thermal Protection System. No Reflective Paint Required.

**DOT 112A400W**

Non-Insulated (Upper 2/3 of Tank Must be painted with Light-Reflective Paint). Safety Valve (300 psi). Alternate setting 330 psi for Certain Commodities

**DOT 112S440W**

Same as DOT 112T400W Except Equipped with Head Protection.

Anhydrous Ammonia

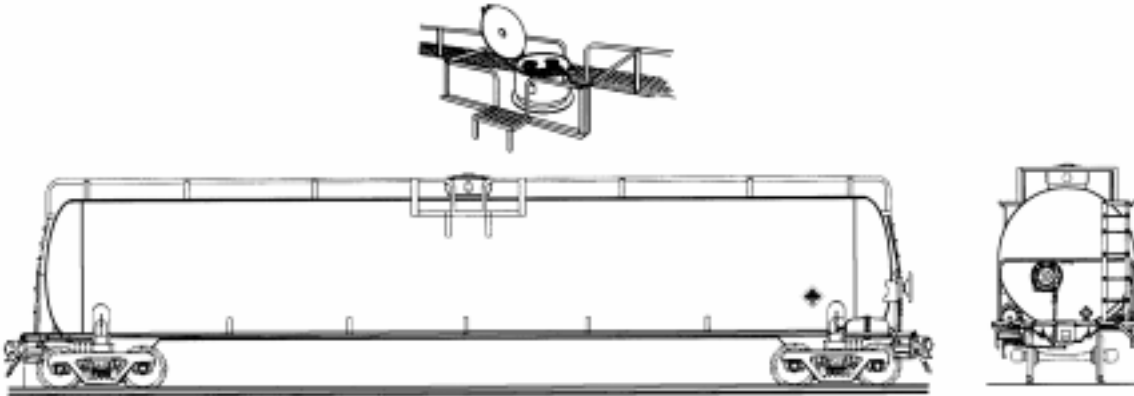
**DOT 112J400W**

33,500 GALLON CAPACITY - NON INSULATED  
DOT 112J400W  
FOR PROPYLENE, LIQUEFIED PETROLEUM GAS  
AND ANHYDROUS AMMONIA SERVICE

Same as DOT 112T400W Except Equipped with Head Protection and a Thermal Protection System. Enclosed in a Metal Jacket. No Reflective Paint Required.

Liquefied Petroleum Gas  
(V.P.) Not Exceeding 300 psi @ 115° F)  
Vinyl Chloride

**DOT 112T400W**

Same as DOT 112T400W Except Equipped with Head Protection and a Non-Jacket Thermal Protection System. No Reflective Paint Required.

**DOT 112A500W**

Non-Insulated (Upper 2/3 of Tank Must be painted with Light-Reflective Paint). Safety Valve (375 psi).

**DOT 112S500W**

Same as DOT 112A500W Except Equipped with Head Protection.

Anhydrous Ammonia

**DOT 112J500W**

Same as DOT 112A500W Except Equipped with Head Protection and a Thermal Protection System. Enclosed in A Metal Jacket No Reflective Paint Required.

Liquefied Petroleum Gas  
Vinyl Chloride

**DOT 112T500W**

Same as DOT 112A500W Except Equipped with Head Protection and a Non-Jacketed Thermal Protection System. No Reflective Paint Required.

**A-10 — Class 113 (Similar to AAR204W)****DOT 113A60W**

Insulated.  
Safety Valve (30 psi) (On Tank).  
Safety Vent (60 psi) (On Tank).  
Safety Vent (16 psi) (On Outer Shell).

Hydrogen

**DOT 113A175W (Obsolete for New Construction, 10-1-84)**

Insulated.  
Gauging Device.  
Safety Valve (115 psi) (On Tank).  
Safety Vent (175 psi) (On Tank).  
Safety Vent (16 psi) (On Outer Shell).

| TANK DESCRIPTION | TYPICAL COMMODITIES TRANSPORTED<br>(typical commodities only listed, there may be others) |
|------------------|---|
|------------------|---|

**A-11 — Class 114A, 114S, 114J and 114T**

**DOT 114A340W**

Non-Insulated (Upper 2/3 of Tank Must be painted with Light-Reflective Paint).  
 Manway and Cover May Not be Located at Top of Tank.  
 Safety Valve (225 psi). Alternate Setting 280.5 psi for Certain Commodities.  
 Bottom Outlet or Washout Optional.

**DOT 114S340W**

Same as DOT 114A340W Except Equipped with Head Protection. Anhydrous Ammonia

**DOT 114J340W**

Same as DOT 114A340W Except Equipped with Head Protection and a Thermal Protection System. Enclosed in a Metal Jacket. No Reflective Paint Required. Liquefied Petroleum Gas

**DOT 114T340W**

Same as DOT 114A340W Except Equipped with Head Protection and a Non-Jacketed Thermal Protection System. No Reflective Paint Required.

**DOT 114A400W**

Non-Insulated (Upper 2/3 of Tank Must be painted with Light-Reflective Paint).  
 Manway and Cover May Not be Located at Top of Tank.  
 Valve and Fittings on Top of Tank.  
 Safety Valve (300 psi). Alternate Setting 330 psi for Certain Commodities.

**DOT 114S400W**

Same as DOT 114A400W Except Equipped with Head Protection. Anhydrous Ammonia

**DOT 114J00W**

Same as DOT 114A400W Except Equipped with Head Protection and a Thermal Protection System Enclosed in a Metal Jacket. No Reflective Paint Required. Liquefied Petroleum Gas

**DOT 114T400W**

Same as DOT 114A400W Except Equipped with Head Protection and a Non-Jacketed Thermal Protection System. No Reflective Paint Required.

**AAR TANK CARS: AAR tank cars are for non-regulated commodity services. Most AAR tank cars have DOT counter parts.**

**B-1 — Class AAR 203**

**AAR 203W (Obsolete for New Construction)**

|   |                |
|---|----------------|
| Non-Insulated or Insulated.                                 | Vegetable Oils |
| Safety Valve (35 <sup>+</sup> psi) or Safety Vent (45 psi). | Fish Oils      |
| These Cars Conform, with Certain                            | Wine           |
| Exceptions, to Class DOT 103W.                              | Clay           |
|   | Latex          |

**B-2 — Class AAR 204 (Similar to DOT 113A)**

**AAR 204W**

|                                       |                 |
|---------------------------------------|-----------------|
| Insulated.                            | Liquid Argon    |
| Safety Valve (38 psi) (On Tank).      | Liquid Nitrogen |
| Safety Vent (45 psi) (On Tank).       | Liquid Oxygen   |
| Safety Vent (17 psi) (On Outer Shell) |                 |

**B-3 — Class AAR 206 (Similar to DOT 115A)**

**AAR 206W**

Tank Cars are Insulated Non-Pressure having an Inner Container. These cars conform, with Certain Exceptions, to Class DOT 115A.

**AAR207A\*\*AW— AAR207A\*\*ALW**

|   |                      |
|---|----------------------|
| Non Insulated or Insulated.                     | Cement               |
| Special Granular Non-Regulatory Commodities.    | Granular Commodities |
| Designed for 15 PSIG Minimum Internal Pressure. |                      |

**ICC TANK CARS**

Beginning in 1968, the currently effective ICC tank car classes were redesigned DOT. However, the marking on existing cars of the affected classes is optional and the majority are still marked ICE. (Tank cars of classes no longer effective for new construction, such as riveted and forge welded, remain with ICC markings. For characteristics and typical commodities, see the corresponding DOT classes)

**THE PRECEDING MATERIAL WAS MEANT TO PROVIDE A GENERAL DESCRIPTION ONLY, NOT COMPLETE SPECIFICATIONS.**

\* Cars built prior to January 1, 1959, may be equipped with (2) 25 psi safety valves.

# Non-Pressure Cars

DOT Car Types 103, 104, 111, 115 And AAR Car Types 204, 206 And 211 Are Non-Pressure Cars. These Cars Are Used To Transport Commodities Such As Corn Syrup, Edible Oils And Other General Commodities As Well As A Variety Of Hazardous Materials. **The Most Commonly Used Non Pressure Cars Are Types 103 And 111. Drawings Of Several (Not All) Of These Two Types Are Found In This Appendix.**

| TANK DESCRIPTION | TYPICAL COMMODITIES TRANSPORTED<br>(typical commodities only listed, there may be others) |
|------------------|---|
|------------------|---|

**A-1 — Class 103**

**DOT 103W**

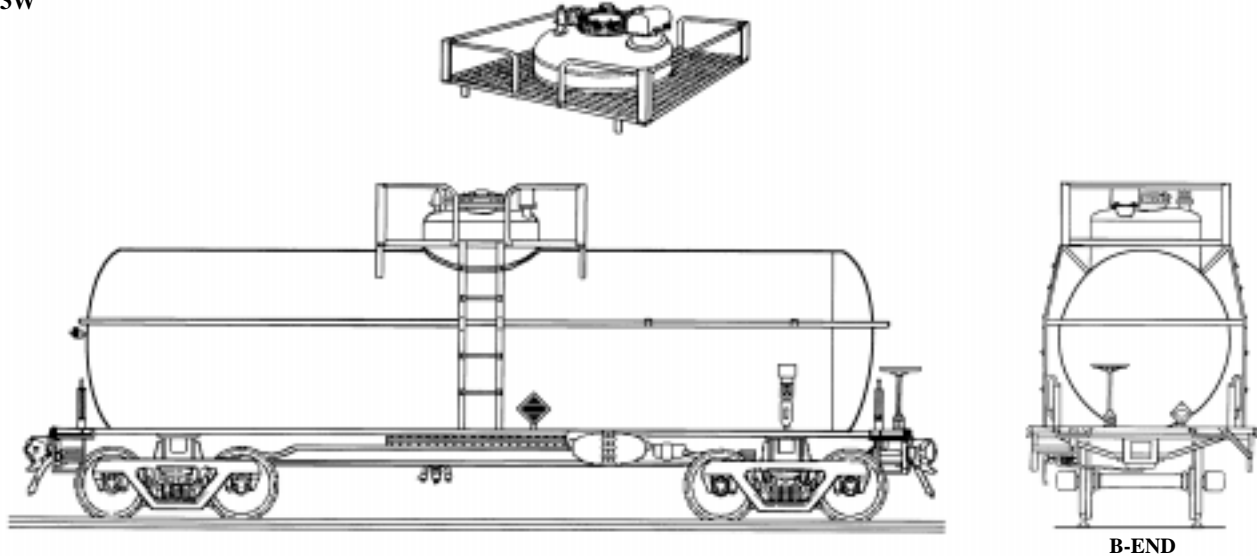

**10,000 GALLON CAPACITY - INSULATED  
FOR GENERAL SERVICE COMMODITIES**

Non-Insulated or Insulated.  
General Service.  
Safety valves (35\* psi) or Safety Vent (60 psi)

Phosphorus, Benzene, Gasoline, Vegetable Oil, Caustic Soda,  
Fuel Oil, Alcohol

**DOT 103AW**

Non-Insulated or Insulated.  
Acid Service.  
Safety valves (35\* psi) or Safety Vent (60 psi).

Sulfuric Acid  
Oleum  
Aqueous Hydrofluoric Acid 60% to 80%  
Titanium Tetrachloride

**DOT 103ANW**

Non-Insulated or Insulated.  
Safety Valve (35\* psi) or Safety Vent (60 psi).

Phosphorous Oxychloride  
Phosphorus Trichloride  
Benzyl Chloride  
Chloroacetyl Chloride

**DOT 103ALW**

Non-Insulated or Insulated.  
Safety Valves (35\* psi) or Safety Vent (60 psi).

Acetic Acid, Acetic Anhydride,  
Acrylonitrile, Ethylene Glycol,  
Glycerine, Butraldehyde,  
Hydrogen Peroxide (Under 52% by weight), Fatty Acids

**DOT 103A-ALW**

Non-Insulated or Insulated.  
Safety Valves (35\* psi) or Safety Vent (60 psi).

Hydrogen Peroxide  
Hydrazine  
Nitric Acid (80% or more)

**DOT 103BW**

Non-Insulated or Insulated.  
Rubber Lined Tank.  
Safety Vent (60 psi).

Hydrochloric Acid not over 38% by weight  
Zinc Chloride  
Phosphoric Acid  
Ferric Chloride  
Aluminum Sulfate

\* Cars built prior to January 1, 1959, may be equipped with (2) 25 psi safety valves.

\*\* Cars built prior to January 1, 1959, may be equipped with 45 psi safety valve.



| TANK DESCRIPTION | TYPICAL COMMODITIES TRANSPORTED<br>(typical commodities only listed, there may be others) |
|------------------|---|
|------------------|---|

|   |  |
|---|--|
| <b>DOT 103CW</b><br>Non-Insulated or Insulated.<br>Safety Valve (35 ** psi) | Nitric Acid<br>Hydrazine<br>Chlorosulfonic Acid<br>Formic Acid |
|---|--|

|   |  |
|---|--|
| <b>DOT 103DW</b><br>Non-Insulated Or Insulated.<br>Safety Valve (35+psi).Or<br>Safety Vent (60 psi) | Acetic Acid, Whiskey<br>Ethyl Alcohol, Caramel<br>Fruit Juices, Vegetable Juices |
|---|--|

|  |   |
|--|---|
| <b>DOT 103EW</b><br>Non-Insulated or Insulated.<br>Safety Valve (35* psi) or Safety Vent (60 psi). | Phosphoric Acid<br>Chlorosulfonic Acid<br>Diisooctyl Acid Phosphate |
|--|---|

**A-2 — Class 104**

|  |  |
|--|--|
| <b>DOT 104W</b><br>Insulated.<br>Safety Valves (35* psi) or Safety Vent (60 psi) | Ethyl Ether<br>Casinghead Gasoline<br>Refined Vegetable Oils |
|--|--|

**A-8 — Class DOT111A**

|   |  |
|---|--|
| <b>DOT 111A60W1 (DOT 111A60F1) *</b><br>Non-Insulated or Insulated.<br>Safety Valve (35 psi) or Safety Vent (60 psi). | Benzene<br>Gasoline<br>Alcohol<br>Caustic Soda<br>Fuel Oil |
|---|--|

|   |  |
|---|--|
| <b>DOT 111A60W2</b><br>Non-Insulated or Insulated.<br>Safety Valve (35 psi) (Required on Certain<br>Commodities) or Safety Vent (60 psi). | Aqueous Hydrofluoric Acid, 60% to 80%<br>Mixed Acid<br>Sulfuric Acid<br>Titanium Tetrachloride |
|---|--|

|   |   |
|---|---|
| <b>DOT 111A60W5</b><br>Non-Insulated or Insulated.<br>Rubber Lined Tank.<br>Safety Vent (60 psi). | Hydrochloric Acid not over 38% by weight<br>Phosphoric Acid<br>Aluminum Sulfate |
|---|---|

|   |       |
|---|-------|
| <b>DOT 111A60W7</b><br>Non-Insulated or Insulated.<br>Safety Valve (35 psi) or Safety Vent (60 psi) | Oleum |
|---|-------|

|   |   |
|---|---|
| <b>DOT 111A60ALW1</b><br>Non-Insulated or Insulated.<br>Safety Valve (35 psi) or Safety Vent (60 psi) | Acetic Acid, Acetic Anhydride, Acrylonitrile, Fatty Acids<br>Ethylene Glycol, Glycerine, Butraldehyde, Hydrogen<br>Peroxide (under 52% by Weight) |
|---|---|

**DOT 111A100W1 (DOT 111A100F1)**

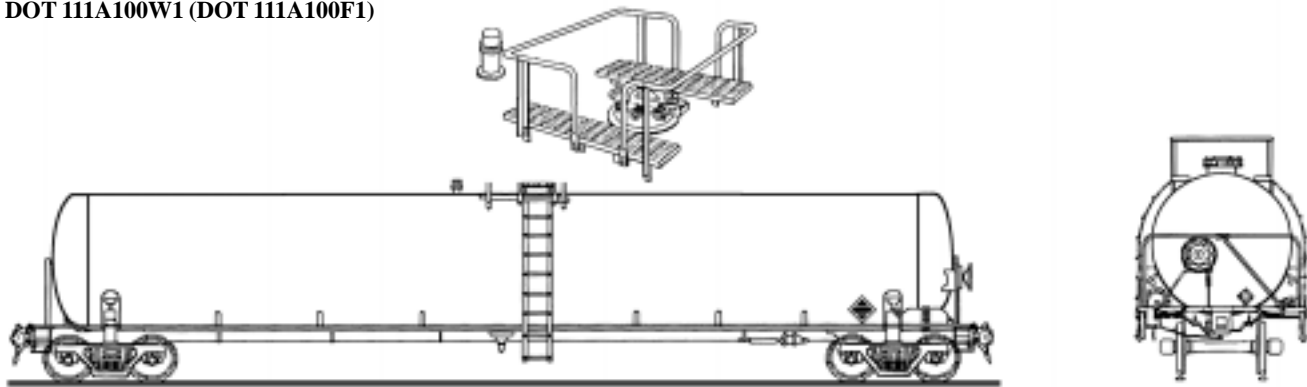

**26,000 GALLON CAPACITY - NON INSULATED**  
**DOT - 111A100W1**  
**FOR GENERAL SERVICE COMMODITIES**  
**.2181"/FT TOP & BOTTOM SLOPE**

|   |   |
|---|---|
| Non-Insulated or Insulated.<br>Safety Valve (75 psi) or Safety Vent (100 psi) | Kerosene, Gasoline, Fuel Oil,<br>Vegetable Oils, Phosphorus |
|---|---|

\* Cars built prior to January 1, 1959, may be equipped with (2) 25 psi safety valves.

\*\* Cars built prior to January 1, 1959, may be equipped with 45 psi safety valve.

**TANK DESCRIPTION**

**TYPICAL COMMODITIES TRANSPORTED**  
(typical commodities only listed, there may be others)

**DOT 111A100W2 (DOT 11A100F2)\***

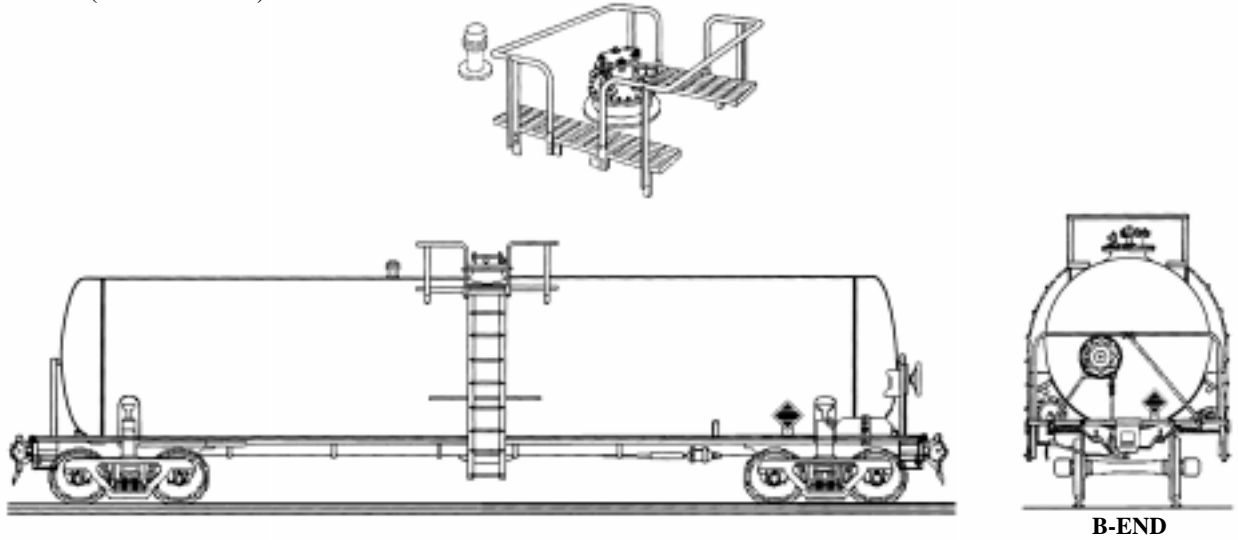

**13,600 GALLON CAPACITY - NON INSULATED**  
**DOT - 111A100W2**  
**FOR SULFURIC ACID SERVICE**  
**(POST 1982)**

Safety Valve (75 psi) or Safety Vent (100 psi)  
Non-Insulated or Insulated.  
Safety Valve (75 psi) (Required on Certain  
Commodities) or Safety Vent (100 psi)

Vegetable Oils, Phosphorus, Aqueous Hydrofluoric  
Acid (60% to 80%), Mixed Acid, Sulfuric Acid

**DOT 111A100W3**

Insulated.  
Safety Valve (75 psi) or Safety Vent (100 psi)

Casinghead Gasoline, Ethyl Ether

**DOT 111A100W4**

Insulated.  
Safety valve (75 psi).

Aqua Ammonia Solution containing Anhydrous Ammonia

**DOT 111A100W5**

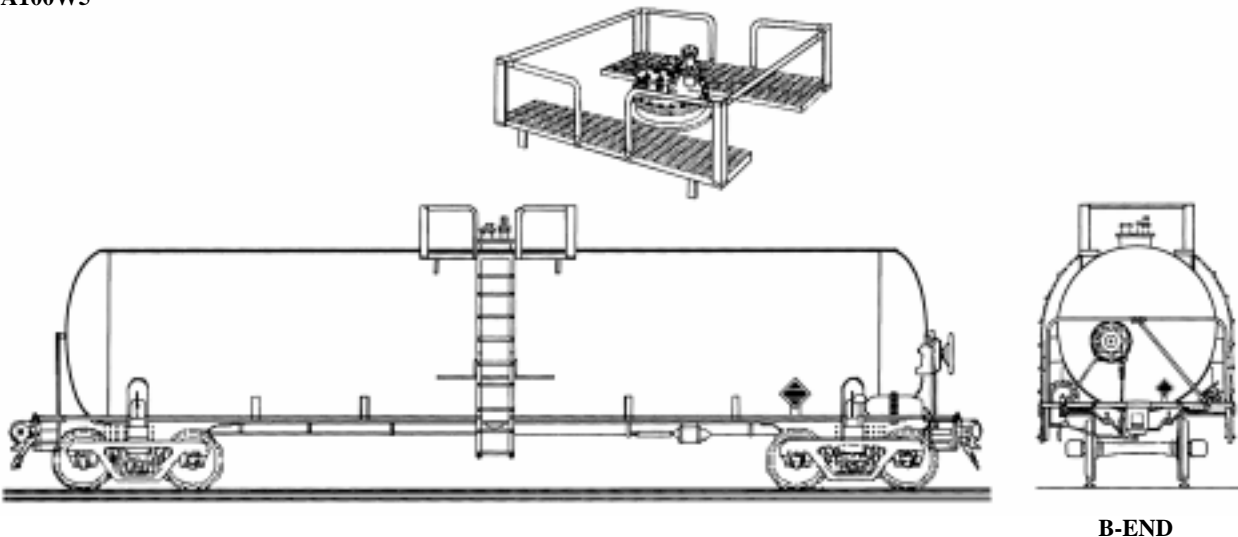

**20,000 GALLON CAPACITY - NON INSULATED**  
**DOT - 111A100W5**  
**FOR HYDROCHLORIC ACID SERVICE**  
**(PRE 1983)**

Non-Insulated or Insulated.  
Rubber-Lined Tank.  
Safety Vent (100 psi).

Hydrochloric Acid not over 38% by weight,  
Phosphoric Acid, Aluminum Sulfate

| TANK DESCRIPTION  | TYPICAL COMMODITIES TRANSPORTED<br>(typical commodities only listed, there may be others) |
|---|---|
| <b>DOT 111A100W6</b><br>Non-Insulated or Insulated.<br>Safety valve (75 psi) or Safety Vent (100 psi).  | Acetic Acid, Caprolactam, Hydrazine,<br>Fruit Juices, Vegetable Juices, Whiskey           |
| <b>A-12— DOT115A (Similar to AAR206W)</b>   |   |
| <b>DOT 115A60W1</b><br>Insulated (Tank-Within-A-Tank)<br>Safety Valve (35 psi) or Safety Vent (45 psi).   | Latex, Methyl Methacrylate (Proposed)   |
| <b>DOT 115A60W6</b><br>Insulated (Tank-Within-A-Tank).<br>Safety Valve (35 psi) or Safety Vent (45 psi).  | Caramel Coloring, Corn Syrup  |
| <b>DOT 115A60ALW</b><br>Insulated (Tank-Within-A-Tank).<br>Safety Valve (35 psi) or Safety Vent (45 psi).   |   |
| <b>AAR TANK CARS: AAR tank cars are for non-regulated commodity services. Most AAR tank cars have DOT counter parts.</b>  |   |
| <b>B-1 — Class AAR 203</b>  |   |
| <b>B-2 — Class AAR 204 (Similar to DOT 113A)</b>  |   |
| <b>AAR 204W</b><br>Insulated.<br>Safety Valve (38 psi) (On Tank).<br>Safety Vent (45 psi) (On Tank).<br>Safety Vent (17 psi) (On Outer Shell)   | Liquid Argon, Liquid Nitrogen, Liquid Oxygen  |
| <b>B-3 — Class AAR 206 (Similar to DOT 115A)</b>  |   |
| <b>AAR 206W</b><br>Tank Cars are Insulated Non-Pressure having an Inner Container. These cars conform, with Certain Exceptions, to Class DOT 115A.  |   |
| <b>AAR207A**AW— AAR207A**ALW</b><br>Non Insulated or Insulated.<br>Special Granular Non-Regulatory Commodities.<br>Designed for 15 PSIG Minimum Internal Pressure.  | Cement<br>Granular Commodities  |
| <b>B-5 — Class AAR 208</b>  |   |
| <b>AAR208</b><br>Non-Pressure Cars having Wood Staved Metal Hooped Tanks for the Transportation of Certain Food Stuffs or Other Acidic Products.<br>Safety Relief Devices are Not Required  | Vinegar<br>Pickle Liquor  |
| <b>B-6 — Class AAR 221A</b>   |   |
| <b>AAR 211A60W1— AAR211A100W1</b><br>Non-Insulated or Insulated.  | Corn Syrup, Molten Sulfur, Edible & Inedible Oils<br>Latex, Wine, Glycerol                |
| <b>AAR 211A60W2— AAR 211A100W2</b><br>Non-Insulated or Insulated.   | Phosphoric Acid, Liquid Alum  |
| <b>AAR 211A100W6</b><br>Non-Insulated or Insulated.   | Caprolactam   |
| <b>AAR 211A60W7</b><br>Non-Insulated or Insulated.  | Lactic Acid   |
| <b>AR 211A60ALW1— AAR 211A100ALW1</b><br>Non-Insulated or Insulated.  | Glycerine, Glycol, Nitrogen Fertilizer Solution   |
| <b>ICC TANK CARS</b><br>Beginning in 1968, the currently effective ICC tank car classes were redesigned DOT. However, the marking on existing cars of the affected classes is optional and the majority are still marked ICE. (Tank cars of classes no longer effective for new construction, such as riveted and forge welded, remain with ICC markings. For characteristics and typical commodities, see the corresponding DOT classes) |   |

**THE PRECEDING MATERIAL WAS MEANT TO PROVIDE A GENERAL DESCRIPTION ONLY, NOT COMPLETE SPECIFICATIONS.**

# DEPARTMENT OF TRANSPORTATION AND AMERICAN ASSOCIATION OF RAILROADS

## STENCIL REQUIREMENTS

**WATER CAPACITY**  
**00000 LBS**  
**00000 KG**  
**(LOCATED IN AREA OF DOME)**

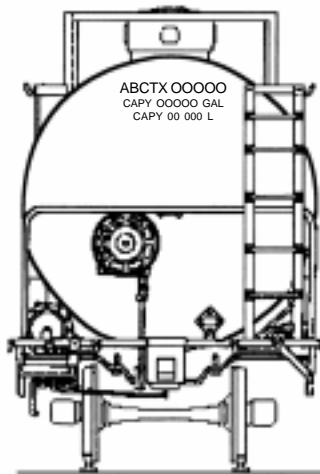
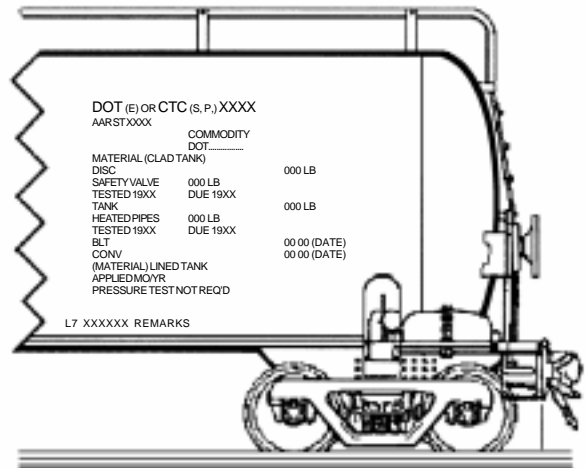
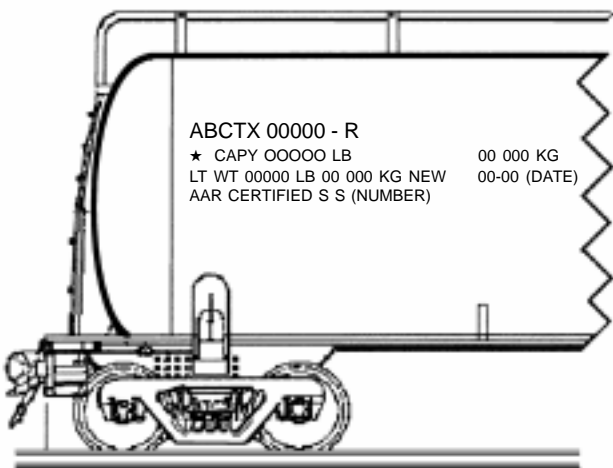

## Other Rail Cars

---

### COVERED HOPPER

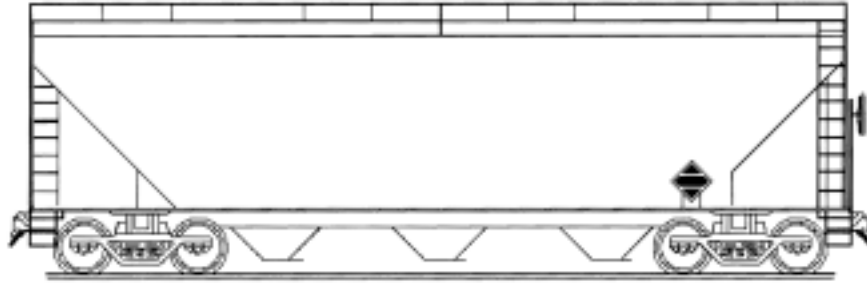

COVERED HOPPER  
CARRIES CALCIUM CARBIDE, CEMENT, GRAIN

---

### OPEN TOP HOPPER

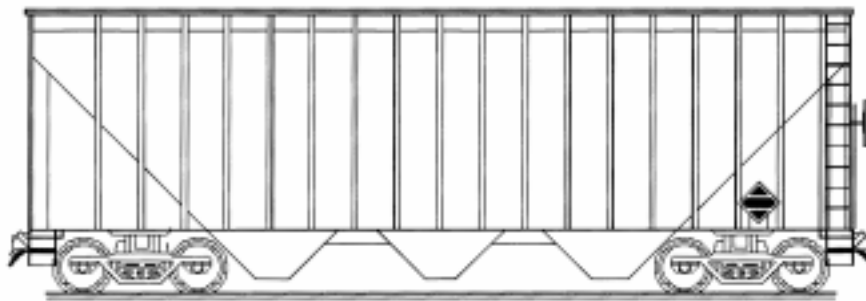

OPEN TOP HOPPER  
CARRIES COAL, ROCK, SAND

---

### PNEUMATIC HOPPER

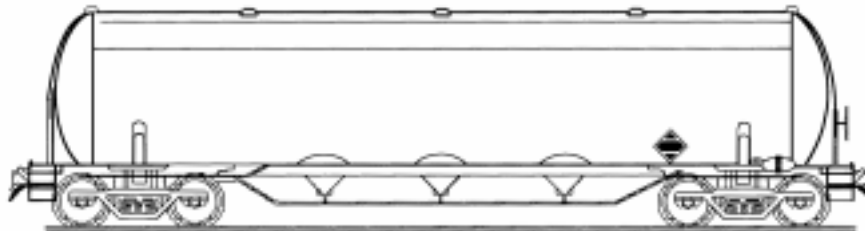

PNEUMATIC HOPPER  
CARRIES PLASTIC PELLETS, FLOUR, OTHER FINE-POWDERED MATERIALS

---

### TUBE CAR

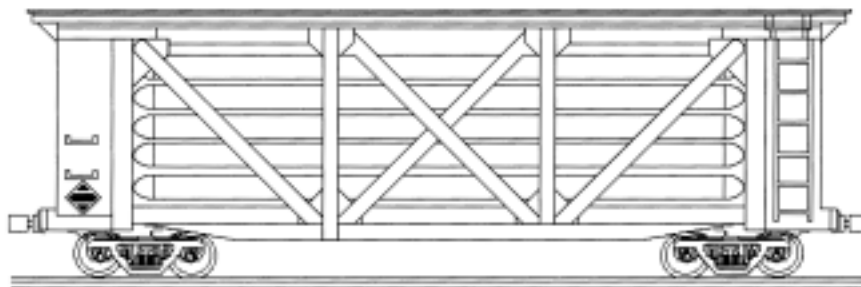

TUBE CAR  
CARRIES HELIUM, HYDROGEN, METHANE, OXYGEN, OTHER GASES

---

**BOX CAR**

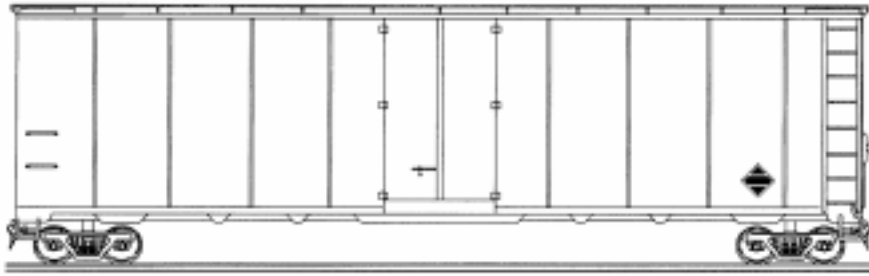

BOX CAR  
CARRIES ALL TYPES OF MATERIAL AND FINISHED GOODS

---

**GONDOLA**

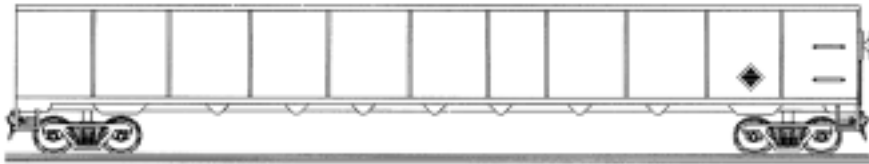

GONDOLA  
CARRIES SAND, ROLLED STEEL AND OTHER PRODUCTS AND MATERIALS  
THAT DO NOT REQUIRE PROTECTION FROM THE WEATHER

---

**FLAT BED CAR WITH INTERMODAL TANKS**

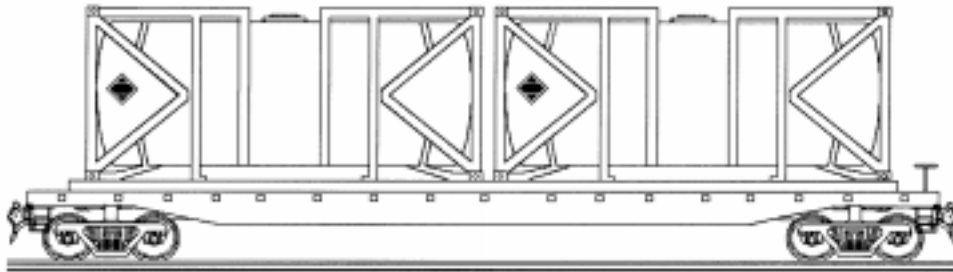

FLAT BED CAR WITH INTERMODAL TANKS  
CARRIES VARIOUS PRODUCTS IN CONTAINERS, I.E., ONE-TON CHLORINE CYLINDERS,  
INTERMODAL CONTAINERS (SHOWN), LARGE VEHICLES, OTHER COMMODITIES  
THAT DO NOT REQUIRE PROTECTION FROM THE WEATHER

---

**CRYOGENIC CAR**

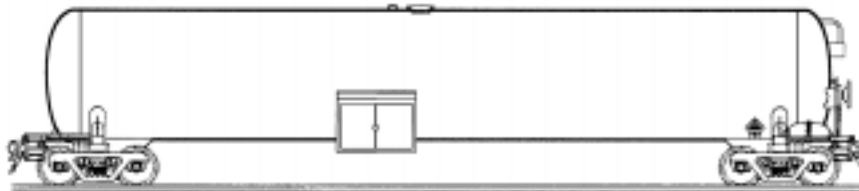

CRYOGENIC CAR  
CARRIES LIQUID OXYGEN, LIQUID NITROGEN, LIQUID CARBON DIOXIDE, LIQUID HYDROGEN,  
OTHER GASES THAT HAVE BEEN LIQUEFIED BY LOWERING THEIR TEMPERATURE

# CARGO TANK TRUCKS

There are many variations and modifications to trailers and tankers. This material is provided as general information on the listed classifications.

| TANK SPECIFICATION\DESCRIPTION | TYPICAL COMMODITIES TRANSPORTED |
|--------------------------------|---------------------------------|
|--------------------------------|---------------------------------|

## DOT 406/MC 306 Non Pressure Liquid Tank

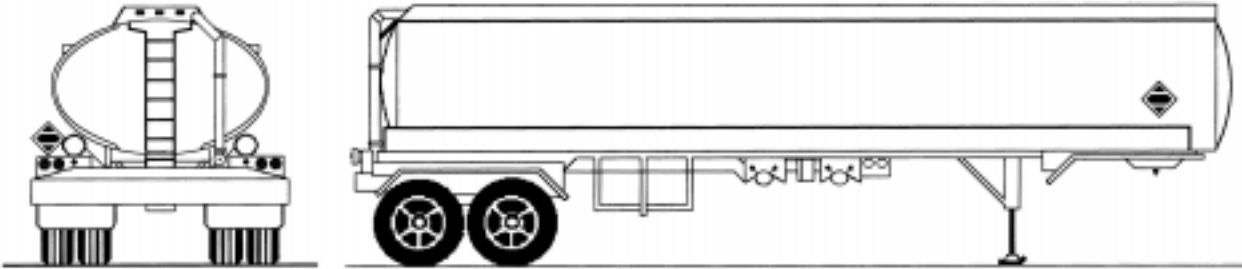

### DOT 406/MC-306 ATMOSPHERIC PRESSURE TANK TRUCK 9,000 GALLONS CAPACITY GENERAL PURPOSE CARGO

OPS Pressure Less Than 3 PSI  
Typical Maximum Capacity 9,000 Gallons  
New Tanks Aluminum  
Older Tanks Steel  
Oval Shape/Multiple Compartments  
Recessed Manholes/Rollover Protection  
Bottom Valves  
Will Likely Have Vapor Recovery

Gasoline,  
Fuel Oil  
Alcohol  
Other Flammable/Combustible Liquids  
Liquids  
Liquid Fuel Products  
(In Non-Coded Tankers)

## DOT 407/MC 307 Low Pressure Chemical Tank

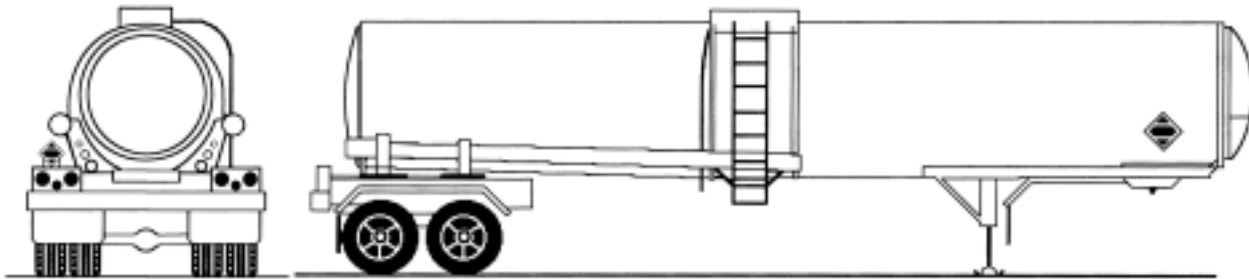

### DOT 407/MC-307 LOW PRESSURE TANK TRUCK 6,000-7,000 GALLONS CAPACITY TRANSPORTS CHEMICALS, FLAMMABLE AND COMBUSTIBLE LIQUIDS

OPS @ 25-40 PSI  
Typical Maximum Capacity 6,000 Gallons  
May Be Rubber Lined/Steel  
Single Or Double Top Manhole  
Single Outlet Discharge For Each  
Compartment At Bottom (Midship Or Rear)  
Typically Double Shell  
Stiffening Rings  
Rollover Protection  
May Be Multiple Compartments  
Horseshoe Or Round Shaped  
Unit Pictured Is Insulated And Covered With Smooth Metal Skin.  
Tank Has Several Stiffing Rings

Flammable Liquids  
Combustible Liquids  
Acids  
Caustics  
Poisons

**MC-312 Corrosive Liquid Tank**

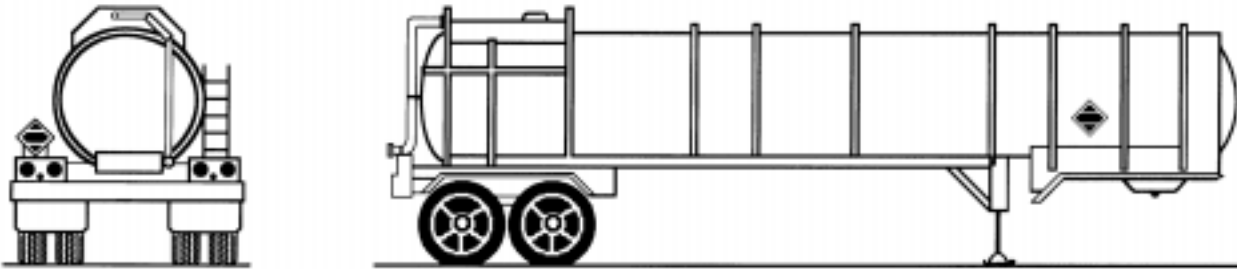

**MC-312 CORROSIVE LIQUID TANK**

OPS Pressure Less Than 75 PSI  
 Typical Maximum Capacity 6,000 Gallons  
 May Be Rubber Lined/Steel  
 Stiffening Rings And Rollover Protection  
 Splash Guard Provides Rollover Protection  
 Top Loading At Rear Or Center  
 Loading Area Typically Coated With Corrosive Resistant Material  
 Small Diameter For Length (Tube Shaped)  
 Typical Single Compartment

Corrosive Liquids  
 Typically Acids

**MC 331 High Pressure Tank**

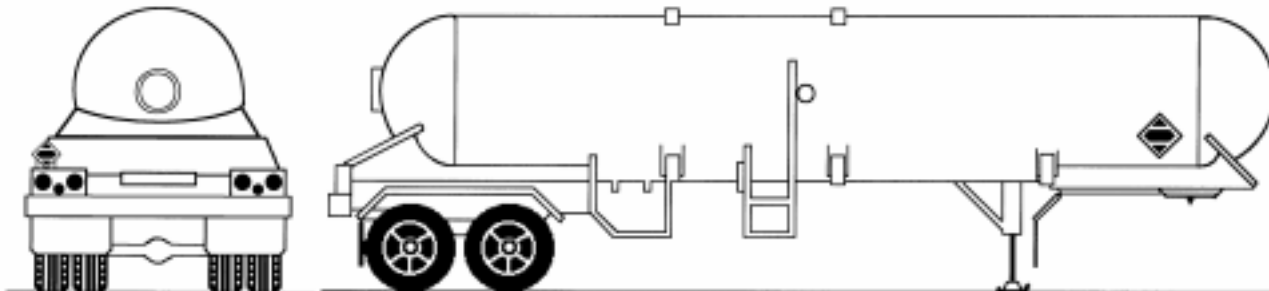

**MC-331 HIGH PRESSURE TANK TRUCK  
 11,500 GALLONS CAPACITY  
 TRANSPORTS LP GAS AND ANHYDROUS AMMONIA**

OPS Pressure Up To 300 PSI  
 Typical Maximum Capacity 11,500 Gallons  
 Steel Single Compartment/Non Insulated  
 Bolted Manhole At Front or Rear  
 Internal and Rear-Outlet Valves  
 Typically Painted White Or Other Reflective Color  
 May Be Marked Flammable Gas and Compressed Gas  
 Round/Dome Shaped Ends

Pressurized Gases & Liquids  
 Anhydrous Ammonia  
 Propane  
 Butane  
 Other Gases That Have Been  
 Liquefied Under Pressure

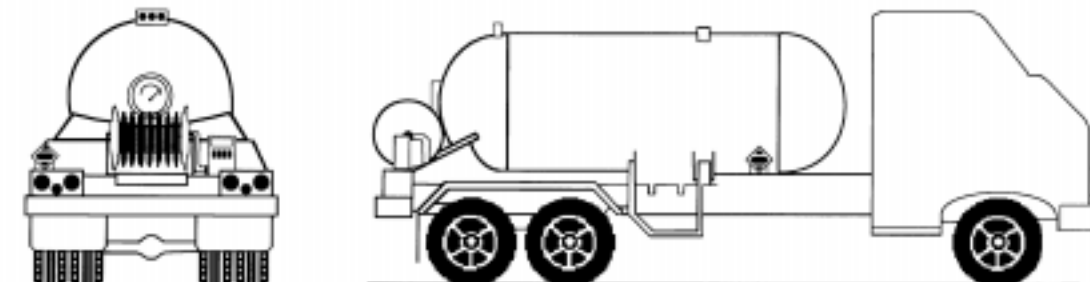

**BOBTAIL TANK — LOCAL DELIVERY OF LP GAS AND ANHYDROUS AMMONIA**



**TANK SPECIFICATION\DESCRIPTION**

**TYPICAL COMMODITIES TRANSPORTED**

**MC338 CRYOGENIC LIQUID TANK**

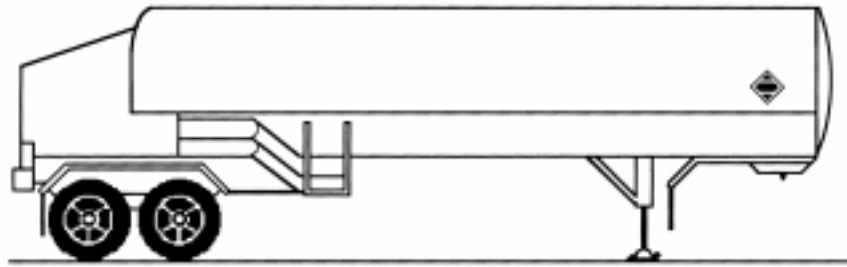
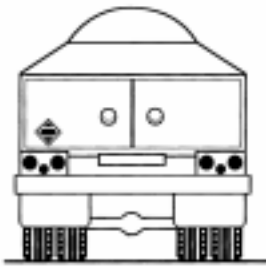

**MC-338 CRYOGENIC LIQUID TANK TRUCK**  
**WELL-INSULATED 'THERMOS BOTTLE' DESIGN**  
**TRANSPORTS LIQUID NITROGEN, OXYGEN, CARBON DIOXIDE, ETC.**

OPS AT Less THAN 22 PSI  
Well Insulated Thermos Bottle Like Steel Tank  
May Have Vapor Discharging from Relief Valves  
Loading/Unloading Valves Enclosed at Rear  
May Be Marked "Refrigerated Liquid"  
Round Tank with Same Type of Cabinet at Rear

Liquid Oxygen  
Liquid Nitrogen  
Liquid Carbon Dioxide  
Liquid Hydrogen  
Other Gases That Have Been Liquefied  
by Lowering Their Temperature

**COMPRESSED GAS/TUBE TRAILER**

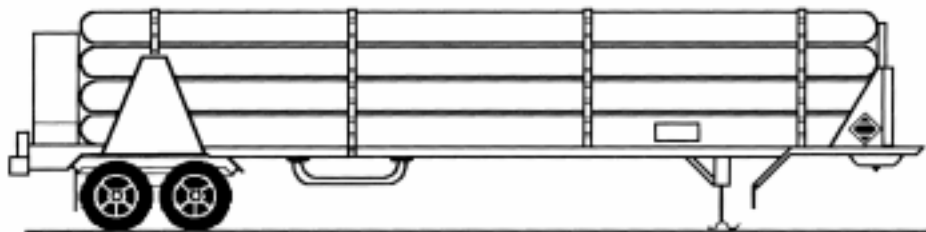
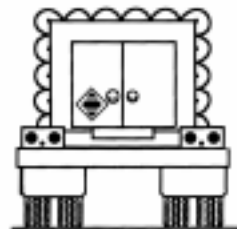
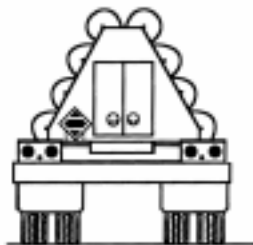

**COMPRESSED GAS TRAILER**  
**3,000-5,000 PSI**  
**TRANSPORTS COMPRESSED GAS**

OPS at 3,000-5,000 PSI (Gas Only)  
Individual Steel Cylinders Stacked and Banded Together  
Typically will have Over Pressure Device for each cylinder  
Valving at Rear (Protected)  
Manufacturer Name May Be on cylinders, i.e. AIRCO, Liquid  
Air, Liquid Carbonic, etc)  
Flat Truck with Multiple Cylinder Stacked in Modular or Nested Shape

Helium  
Hydrogen  
Methane  
Oxygen  
Other Gases

**DRY BULK CARGO TANKER**

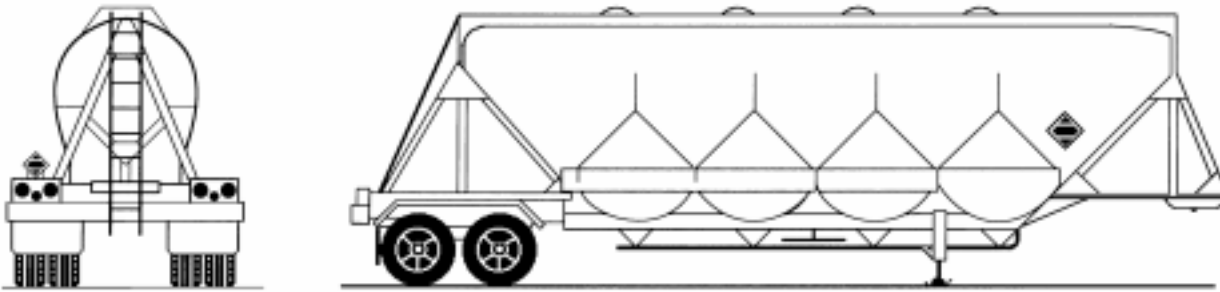

**DRY BULK CARGO TANKER**

Typically Not Under Pressure  
 Over the Road  
 Top Side Manholes  
 Bottom Valves/Air Assisted Loading/  
 Unloading  
 Shapes Vary, But Will Have Hoppers

Calcium Carbide  
 Oxidizers  
 Corrosive Solids  
 Cement  
 Plastic Pellets  
 Fertilizers

**INTERMODAL CONTAINERS\*\***

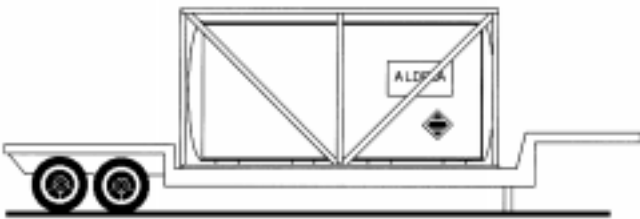

**NON-PRESSURE OR PRESSURE TANK**

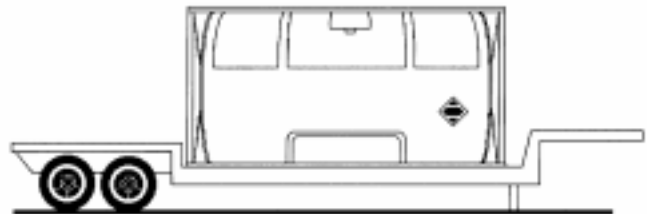

**CRYOGENIC TANK**

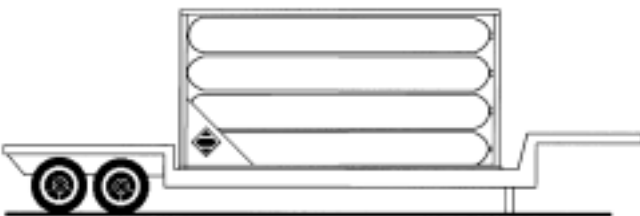

**TUBE MODULES**

\*\* ALL THREE TYPES MAY ALSO BE FOUND ON RAIL CARS OR ABOARD SHIPS

# Storage Tanks

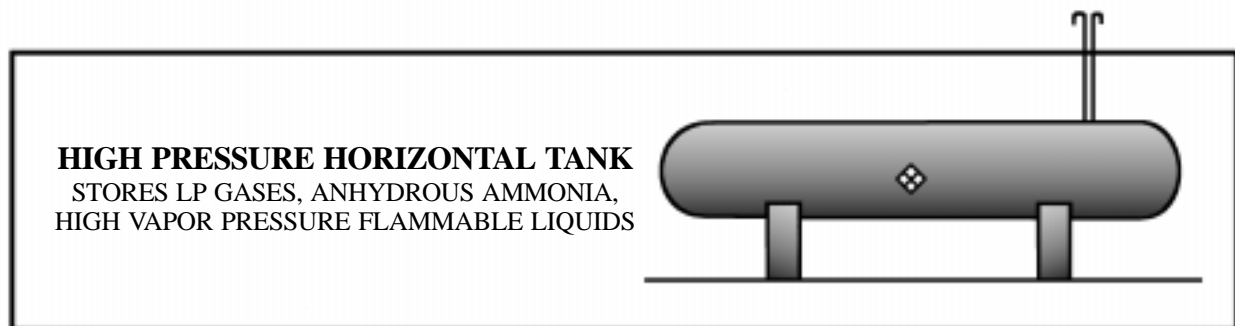
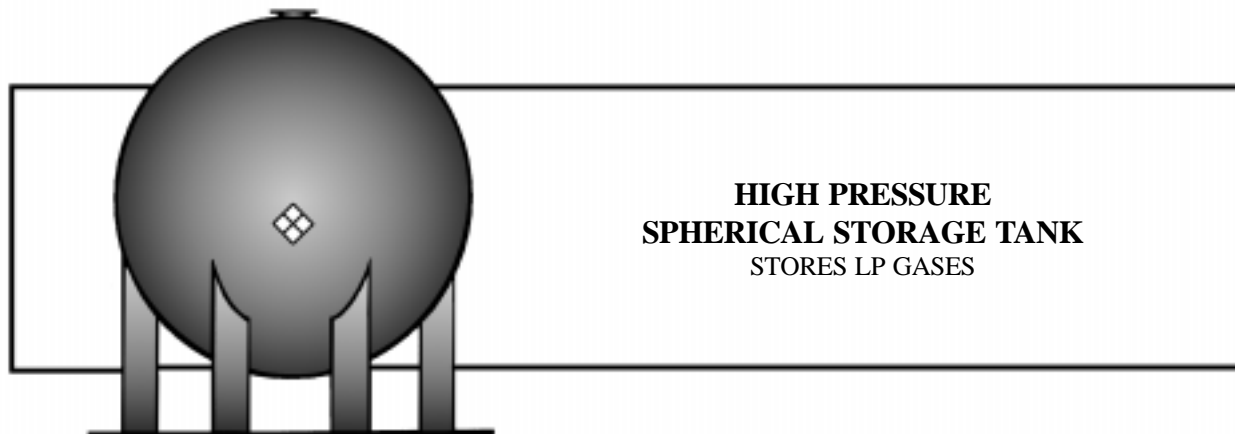
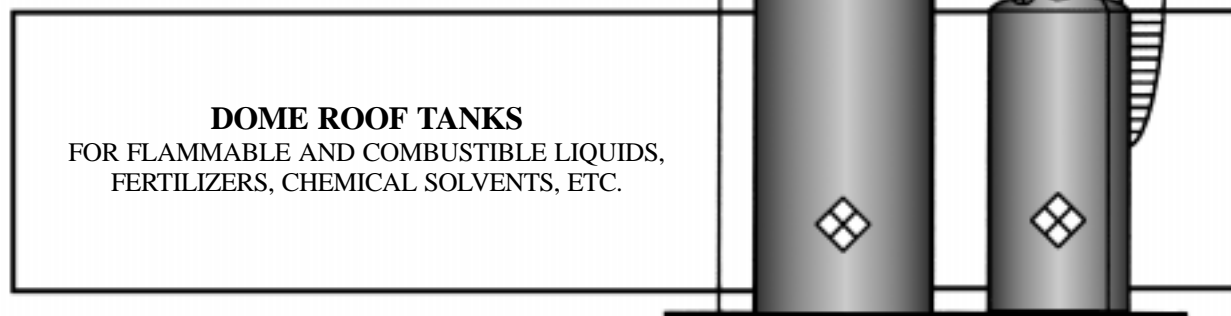
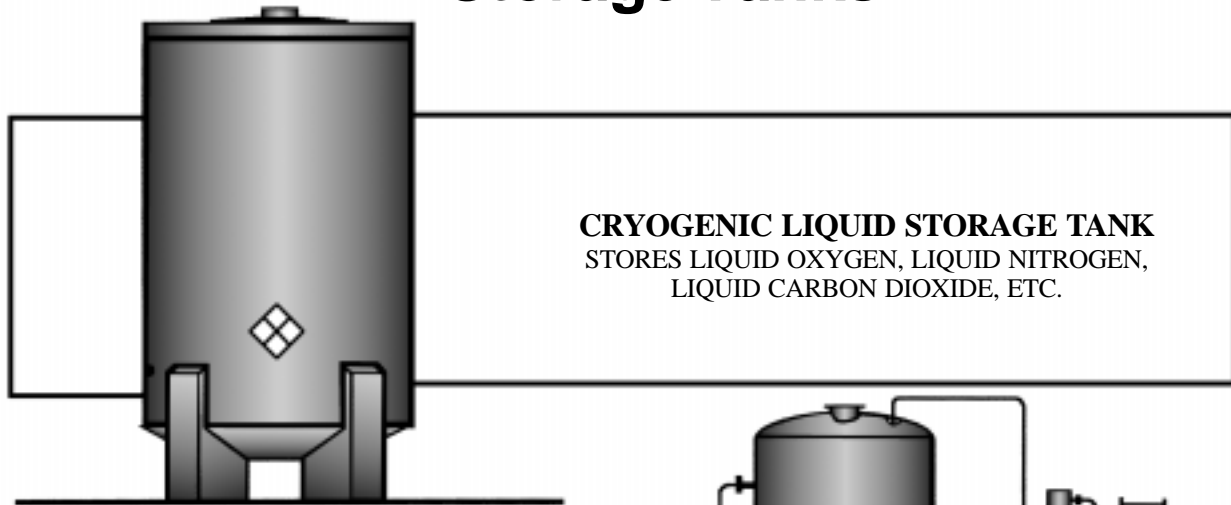

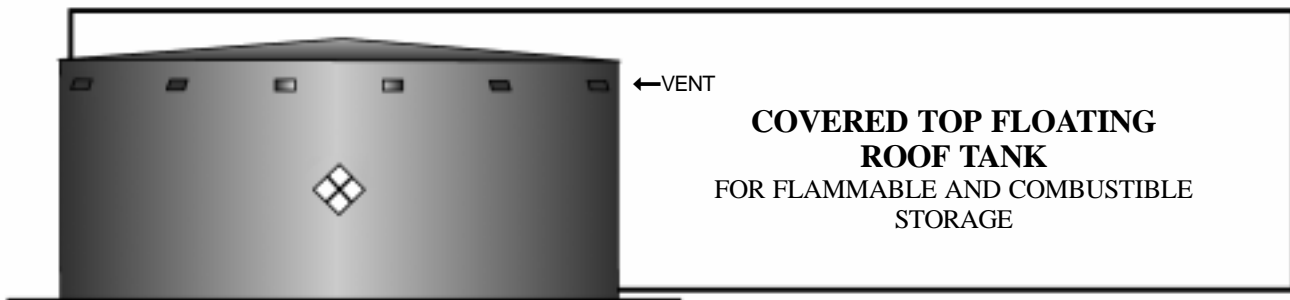
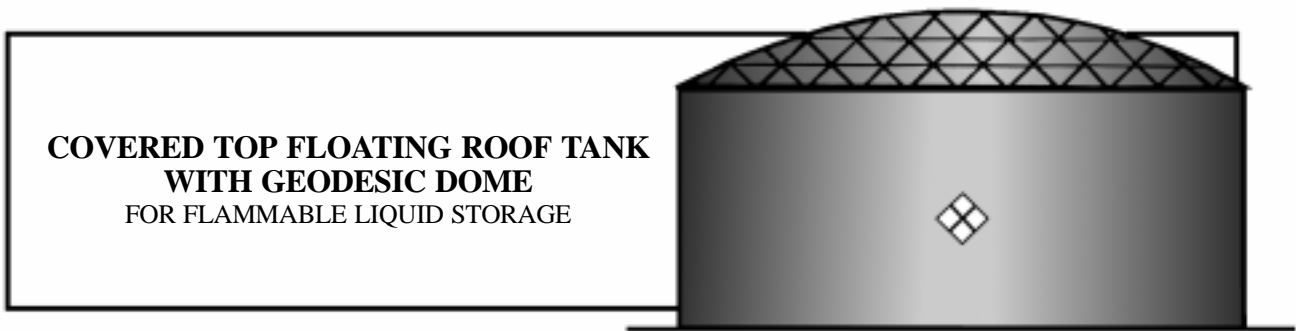
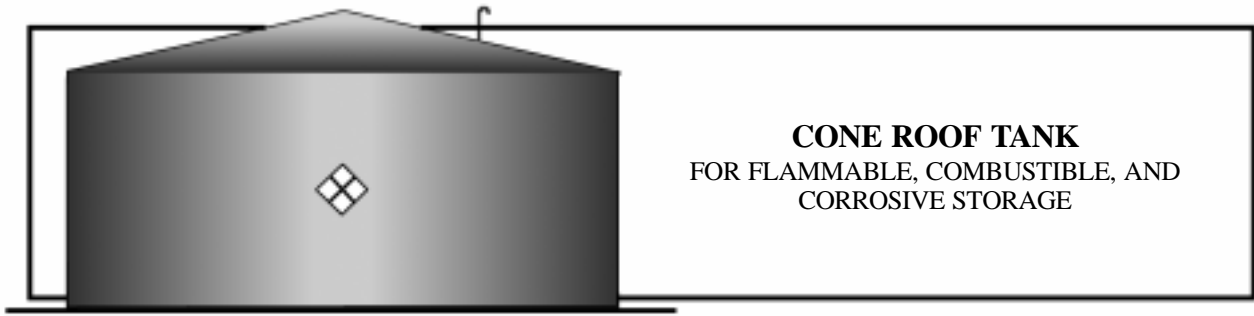

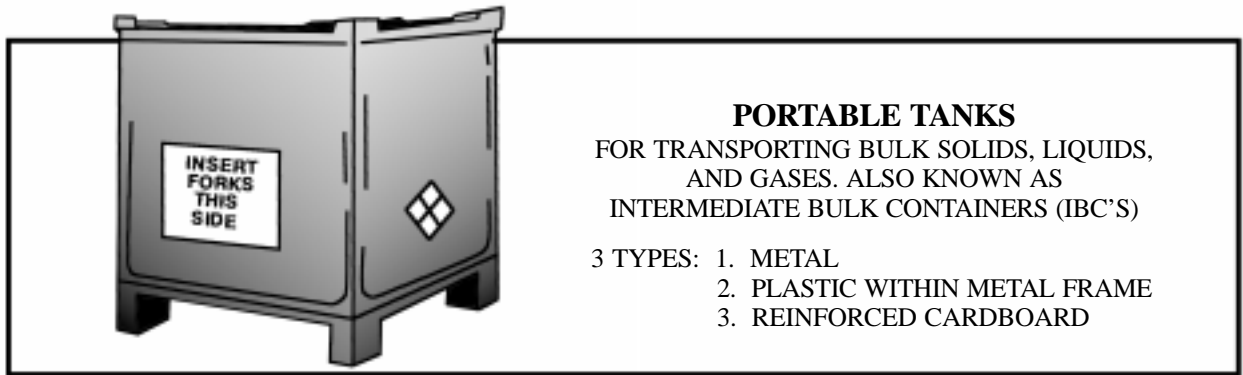

### **PORTABLE TANKS**

FOR TRANSPORTING BULK SOLIDS, LIQUIDS,  
AND GASES. ALSO KNOWN AS  
INTERMEDIATE BULK CONTAINERS (IBC'S)

- 3 TYPES: 1. METAL  
2. PLASTIC WITHIN METAL FRAME  
3. REINFORCED CARDBOARD

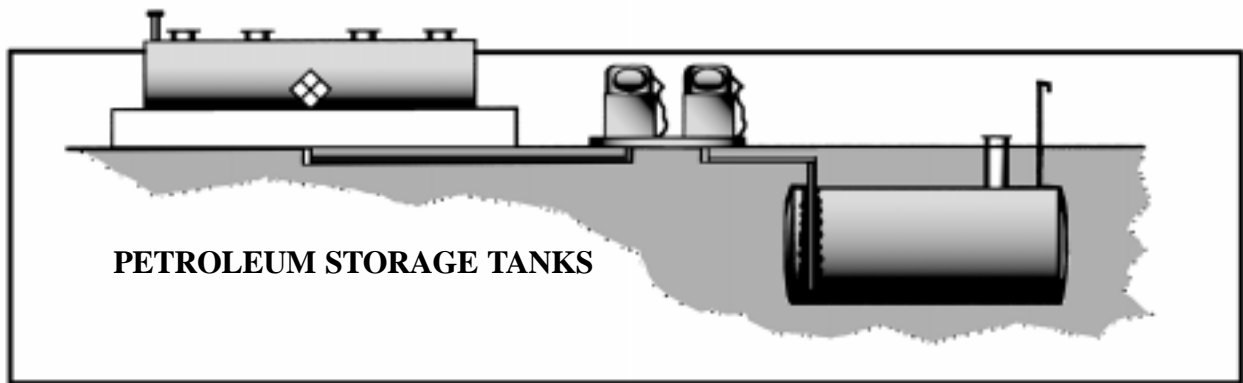

### **PETROLEUM STORAGE TANKS**

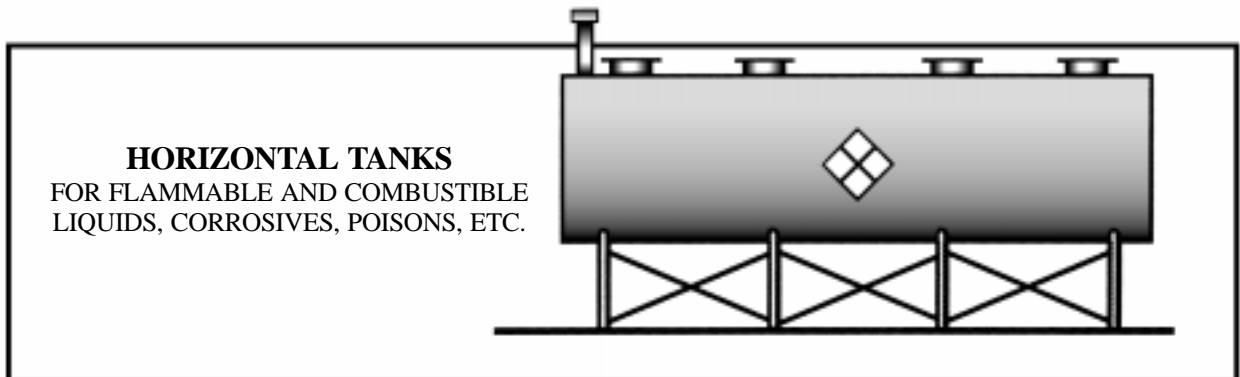

### **HORIZONTAL TANKS**

FOR FLAMMABLE AND COMBUSTIBLE  
LIQUIDS, CORROSIVES, POISONS, ETC.